

Advance®

automation

Digital Servo Metal Ladling Systems



The World of Automation and Consumables Solutions

Let's Discuss How Shot Size Repeatability Saves You \$MONEY\$

Independent customer testing has found that **ADVANCE** ladlers have a repeatable accuracy higher than our advertised 99+%. This is achieved by our superior manufacturing process described in the following pages.

ADVANCE designs its ladlers for the highest repeatability, which means lower cost of operation. For example, let's compare a 60-second cycle operation for 5 days, 20 hours per day, using a 10-pound nominal pour. Now let's compare a competitor's ladler of 10% pouring repeatability against **ADVANCE**'s 1% repeatability guarantee.

Competitor's ladler 10% repeatability for a 10 pound casting:
60 second shot X 20 hours X 5 days = 6,000 shots per week or 60,000 pounds of aluminum. The shot weight variation would be from 60,000 pounds to 66,000 pounds (10 % maximum variation) or 6,000 pounds too much. Let's say, however, the excess average is half of that or 3,000 pounds of aluminum per week.

Now, compare to **ADVANCE**'s 1% repeatability:
The average shot weight variance is 300 pounds per week.

The metal saving difference is 2,700 pounds per week!

At 50 weeks per year, that's equal to 135,000 pounds of metal you've purchased, inventoried, and melted unnecessarily. And figures are only for a 10-pound casting!



What is this costing your company!?!

One die caster stated that a biscuit 1" longer than needed (on a 2-1/2" diameter sleeve) costs about \$50,000 a year (per machine) in remelt costs. You can't afford not to have the most accurate ladler in the industry.

How Does ADVANCE Achieve 99+% Pouring Accuracy in Its Ladlers?

The 99+% is achieved because the ladle cup spill off angle is controlled by the servo motor and servo drive. One revolution of the ladle cup is divided into almost 2 million parts (1,966,000 to be exact). What this means is that the cup spill off angle can be controlled to 2 millionth of its rotation and it's this repeatability of the spill off angle that achieves the ladlers' shot size repeatability.

Unlike other ladlers, the ADVANCE ladler achieves the same repeatability regardless of metal draw down.

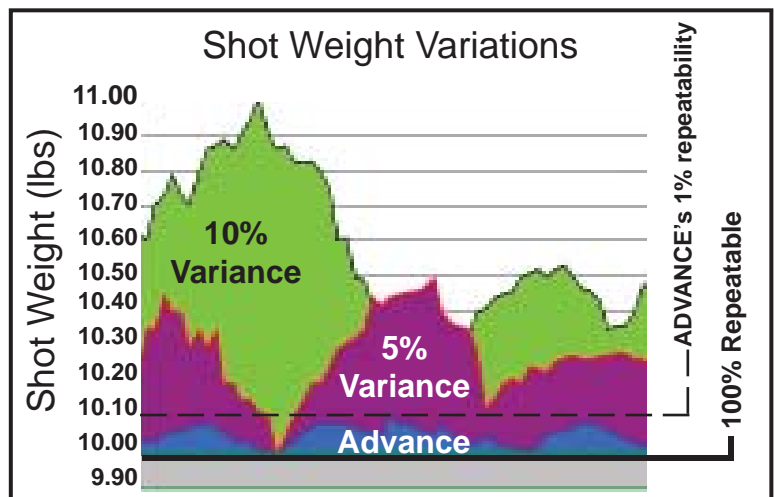

Advance's Design Capabilities Gives You Quality, Low Replacement Costs, and Higher Up-Time

On average, companies spend under \$300 per year on **ADVANCE** ladlers after the warranty period. Why?

ADVANCE design its products starting with 3D solid modeling software. The design criteria set by our president is to design the product so it never breaks down! That's a tough goal, but the minimal amount of money that companies spend with us on replacement parts proves the ladlers are very well designed.

An example of this quality is **ADVANCE's Direct-Drive System.**

Provides nine times the tooth contact of normal gear boxes

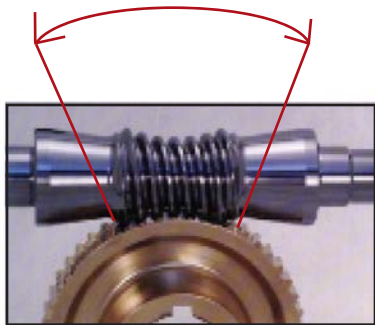

The gear box in **ADVANCE** ladlers is either a ground helical gear set or a Cone Drive double-enveloping gear set where the worm is manufactured in an hour-glass configuration and wraps around the worm wheel. Either provides low backlash and extremely long life. The brushless servo motors are directly coupled to the gearset reducing service drive train problems and improving mechanical response to the servo motors.

The output shaft of the ladler linkage arms is a large, one-piece shaft, which goes completely through the gear box. The positioning encoder, motor, and gearbox are giving direct drive without use of pulleys, belts, or cams.

Heavy-Duty Arm Support

On SL-2000 and larger models (more than 50 pounds of metal), the entire arm assembly is supported by a large housing with double opposed



Timken tapered roller bearings. This housing assembly supports the total weight of the arm so there is no load applied to the gear box assembly, allowing very smooth arm travel without torque interruptions.



Without the weight of the arm being supported by the gearbox, the gear box works for many years.

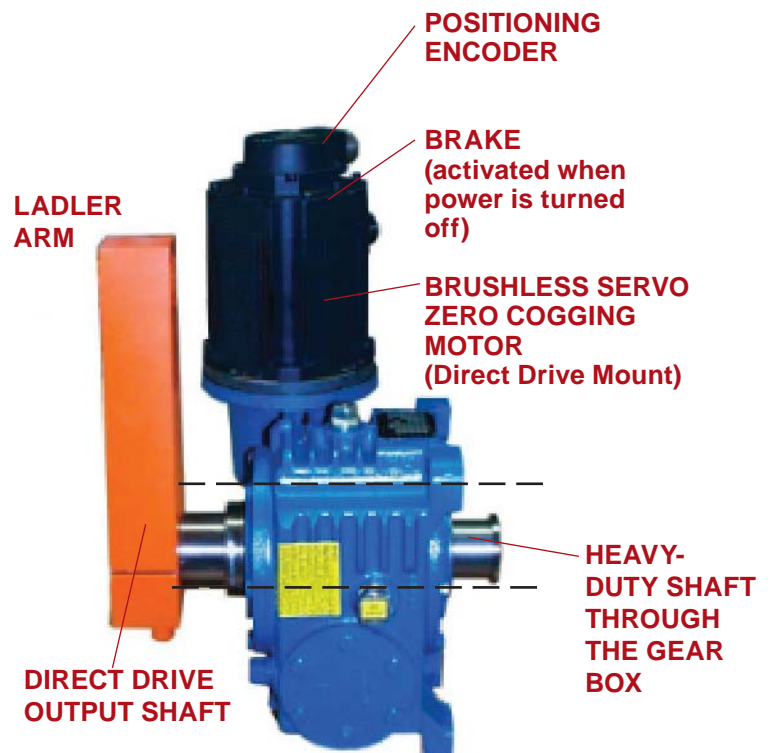

NO DUNKING Smart Probe™ System

ADVANCE has developed proprietary circuitry that prevents dunking. The smart probe remembers the furnace metal position from its last pour pickup. A back up probe is activated if the primary probe fails. If both probes fail, the ladler is programmed to go no more than 1" lower than the previous metal pickup point. If it doesn't sense the metal, it goes to its home position and turns itself off. The ladler doesn't dunk, even if all the probe wires are broken.

The Advance Smart Probe™ System consists of three probes: standard, backup, and smart. Should the standard probe fail, a backup probe takes over to prevent dunking of the arm into metal. Warning lights flash on the Operator Interface Station, signaling a probe failure. Additionally, a smart probe remembers the last metal level detected and allows the probes to advance only 1" below the last metal level sensed. If the smart probe doesn't sense metal within 1", the ladler will dump all the metal in the cup back into the dipwell and return to the home position before shutting itself off automatically.



THE PROBE ASSEMBLY CAN BE MOUNTED ON EITHER SIDE OF THE ARM.

DOUBLE INSULATED WIRES FOR EACH PROBE.

SUPER HIGH TEMPERATURE BEARINGS REQUIRE NO LUBRICATION OR GRAPHITE POWDER.

PROBE TIPS ARE EASILY REPLACEABLE AND TREATED WITH ADVANCE'S EXCLUSIVE ADWEAR TREATMENT, WHICH RESISTS ALUMINUM FOR MONTHS AND SOMETIMES YEARS. THE PROBES DO NOT REQUIRE A COATING.

**50 POUND AND LARGER LADLER SIZES USE INTERCHANGEABLE LADLE CUP ADAPTERS.
ADVANCE LADLERS ARE DESIGNED TO USE ADVANCE QUICK-CHANGE LADLE CUPS.**

Electronic Platform, Construction, and Features

ADVANCE uses standard Mitsubishi components. The human-machine interface, amplifier, and motor are all standard, off-the-shelf Mitsubishi components. No special proprietary electronics with **ADVANCE**. Mitsubishi is #1 worldwide in servo system reliability and **ADVANCE** is proud to partner with them.

Computer Front End

The **Advance** Servo Ladler operator station uses an easy-to-read color 5.75" LCD.

Each program is easy to set up and is menu prompted so even operators with little or no previous programming experience can program the ladle. The unit stores up to 500 parts programs in NV RAM.



Operator Interface Station

The Operator Interface Station allows the operator to monitor the status of the ladler and the metal level in the furnace and control all basic ladler functions. Warning lights signal probe failures, low metal levels, and aborted cycles. Indicators signal the mechanism position and ladle cup status. The Operator Interface Station size is 9" H x 13" W x 4.38" D.

Controls can be set to Manual or Auto by turning a selector switch. A selector switch increases or decreases the shot size.

Main Control Box

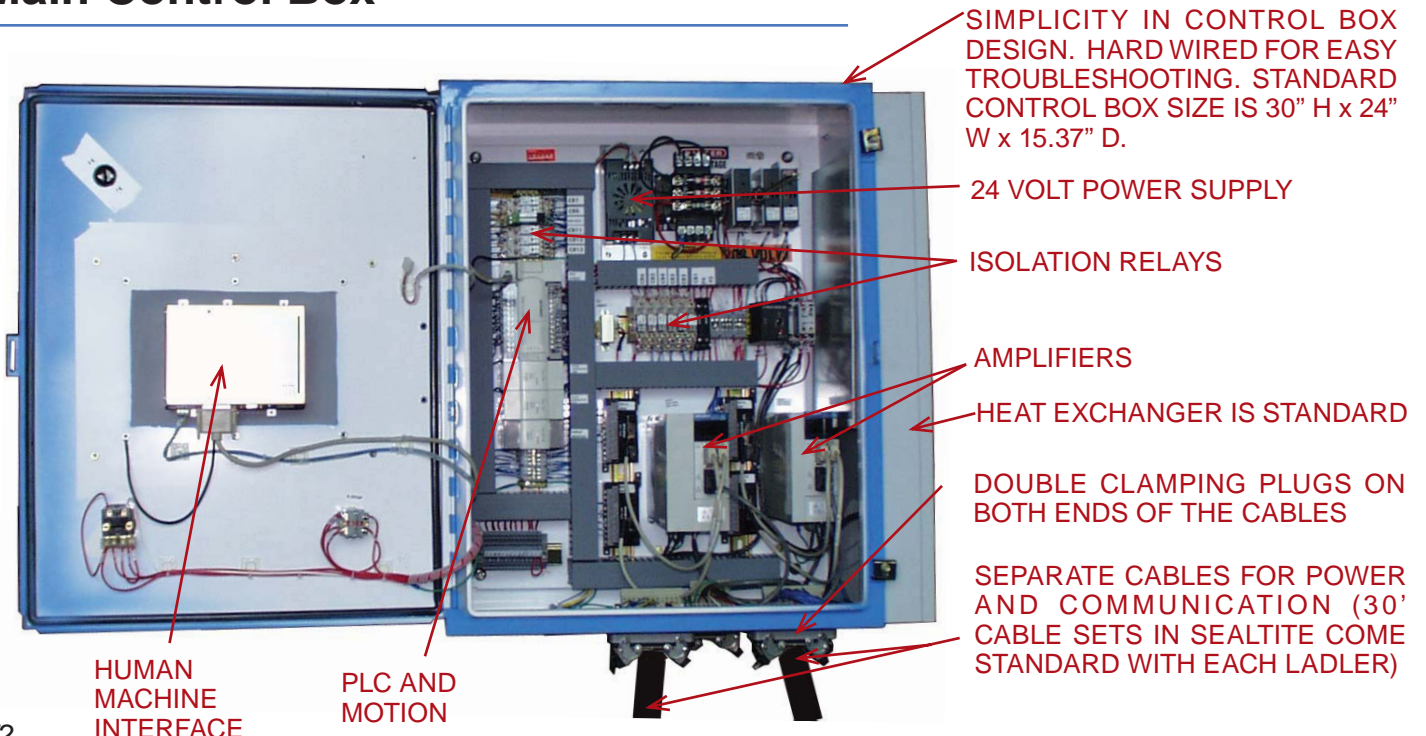

Ladler Major Parts SL-650, SL-1200, SL-1500

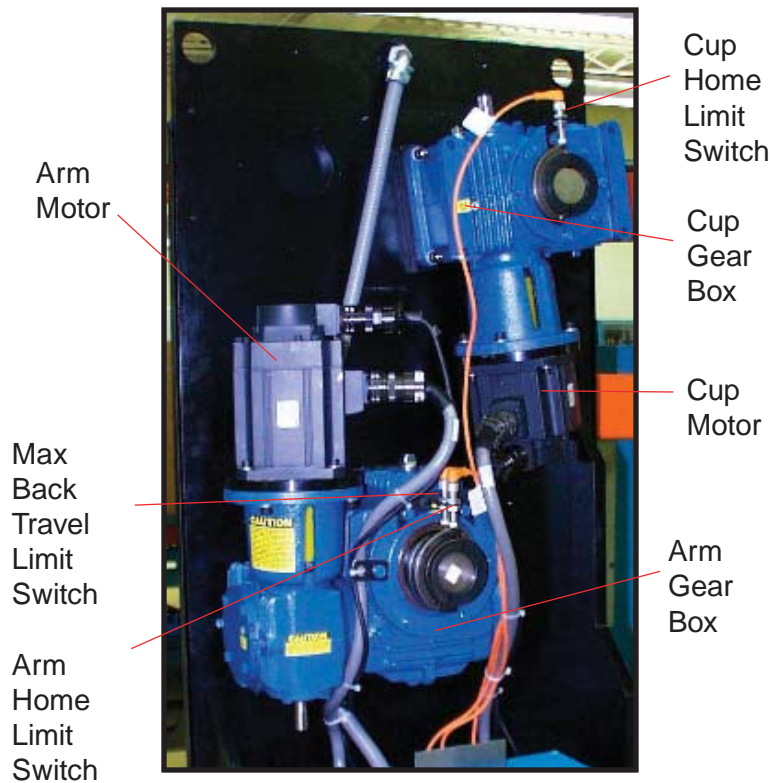

Massive arm links with timken tapered roller bearings at each Joint.



Direct drive systems with servo motor and encoder mounted directly to the gear box.

Sizing Your Ladler Needs

How do I know what ladler size is the correct one for my application? The Quick Reference Ladler Sizing Matrix chart will get you to the general area.

Now determine your maximum shot size: 5#, 15#, 25#, 50#, 100#, or 175#.

ADVANCE ladlers come in several live metal capacities, so check the one that matches your requirements. Now, determine the stroke you need. The drawings on the next two pages give you the stroke. Here's where our planning sheet comes in handy. Just fill out a few dimensions and we'll submit a 3D drawing for your review.

Pouring height from the furnace makes a difference. **ADVANCE** has both standard (level pour) and low pour ladlers where the metal pour position is lower than the metal level. In extreme cases, for those customers who want to pour from a ladler system to larger size die casting machines, say 1,200 ton, **ADVANCE** offers the SL-1400 ladler, which has a metal height range of almost 5'.

ADVANCE offers several choices of tilting bases as part of the **ADVANCE** ladler system. The tilt bases allow for easy pouring position adjustment. See the section on pedestals and tilts for more information.

QUICK REFERENCE LADLER SIZING MATRIX										
400T	600T	800T	1000T	1200T	1400T	1600T	2000T	2500T	3000T	3500T
SL-650										
	SL-1200									
	SL-1500									
				SL-2000						
						SL-3000				
									SL-4000	
Advance makes an SL-1400 for 800-1400T DCM with launder systems.										

LADLER - PLANT SURVEY



Advance Products Corporation - 2527 M-63 Benton Harbor, Michigan 49022
Phone (269) 849-1000 - Fax (269) 849-2200 - www.advanceproductscorp.com

LADLER - PLANT SURVEY

Return to Sales Department:
Date: _____

Company Name: _____

Contact Person: _____

Address: _____ City: _____

State/Zip: _____

Phone: _____ Fax: _____

E-mail Address: _____

DCM Manufacturer: _____

DCM Model: _____ DCM Tonnage: _____

Approx. max. shot size (weight): _____

Plant Voltage(circle one): 208 230 380 440 460 480 575 other: _____



DCM I/O signal voltage: 24vdc 120Vac

Cable Length: (Power & Control) 30' Standard. Cable Length (Power & Control) Nonstandard length: _____ Note: (Additional cable length may incur extra charge.)
Remote Operator Cable Length is Standard at 30'. Consult sales department if you need a special cable length.

Which side of DCM is the dip well on: Operator Helper

Are there any obstructions between the dip well and DCM?

Please add additional pertinent information below and fill in the dimensions highlighted with red arrows on the back side of this form. Thanks!

Your "Window to the World"™ of Die Casting Automation and Consumable Products

6-11-04

3D Views of Typical Ladler Layouts

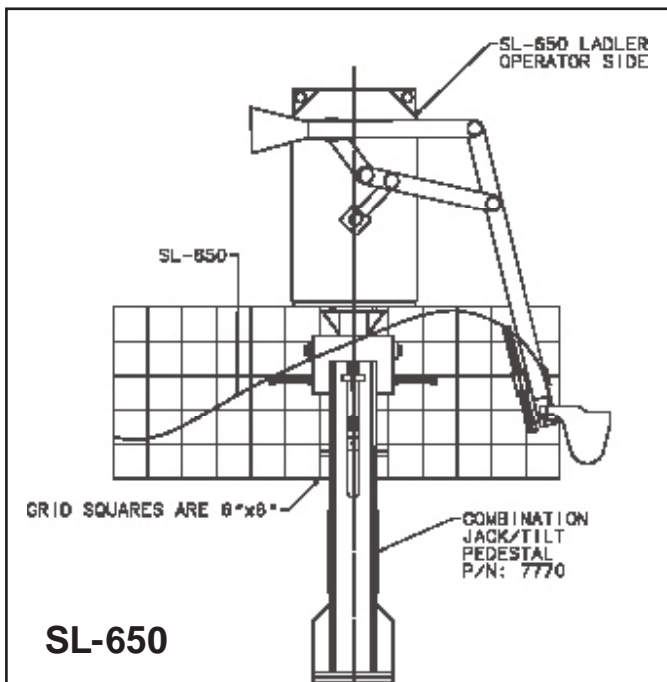
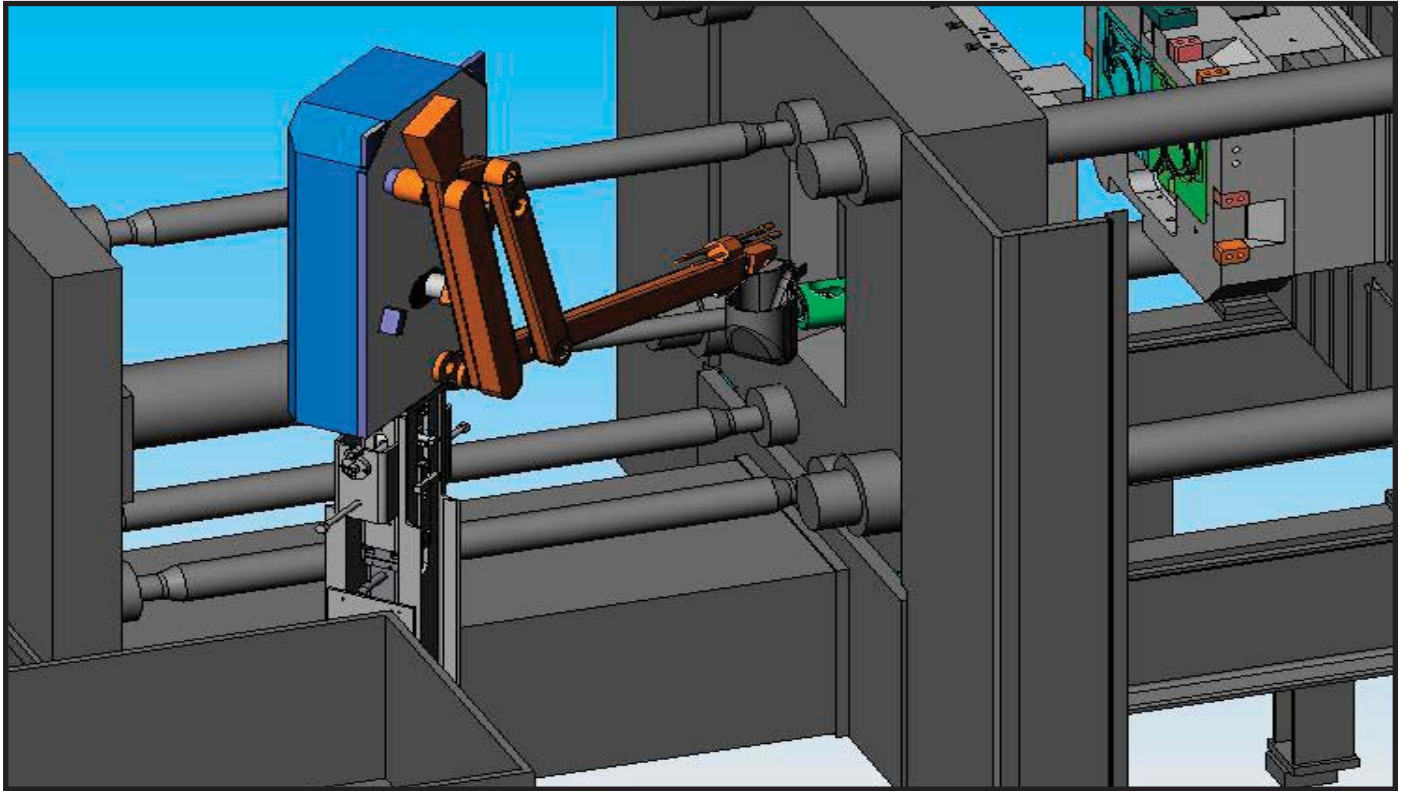

SL-650

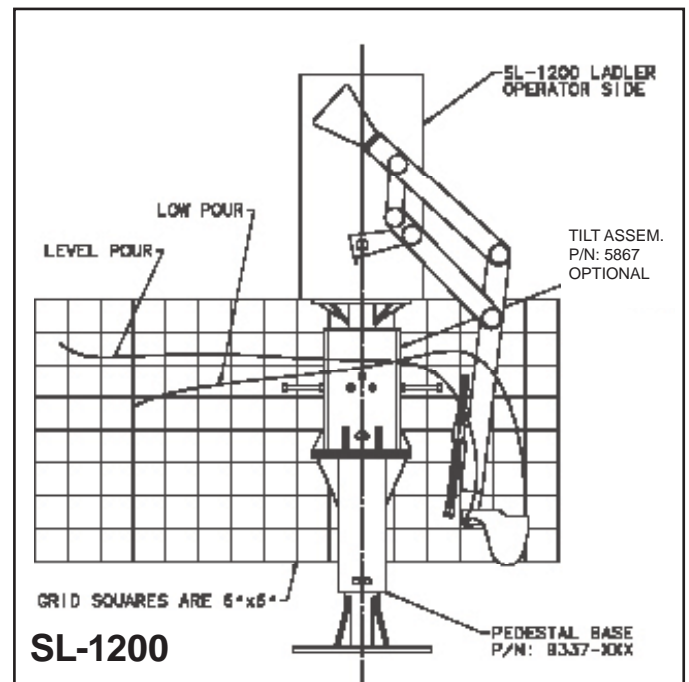

SL-1200

MODEL NUMBER	SL-650
Total Stroke - Max.	69.2 in.(176 cm)
Forward Stroke - Max.	35.5 in. (90 cm)
Live Weight Metal	15 lb. (6.8 Kg)
Reach Back (Furnace)	33.7 in. (86 cm)

MODEL NUMBER	SL-1200 (Lev)	SL-1200 (Low)
Total Stroke - Max.	71 in.(180 cm)	72 in.(183 cm)
Forward Stroke - Max.	50 in. (127 cm)	42 in. (107 cm)
Live Weight Metal	25 lb. (10 Kg)	25 lb. (10 Kg)
Reach Back (Furnace)	21 in. (53 cm)	30 in. (76 cm)

Specifications

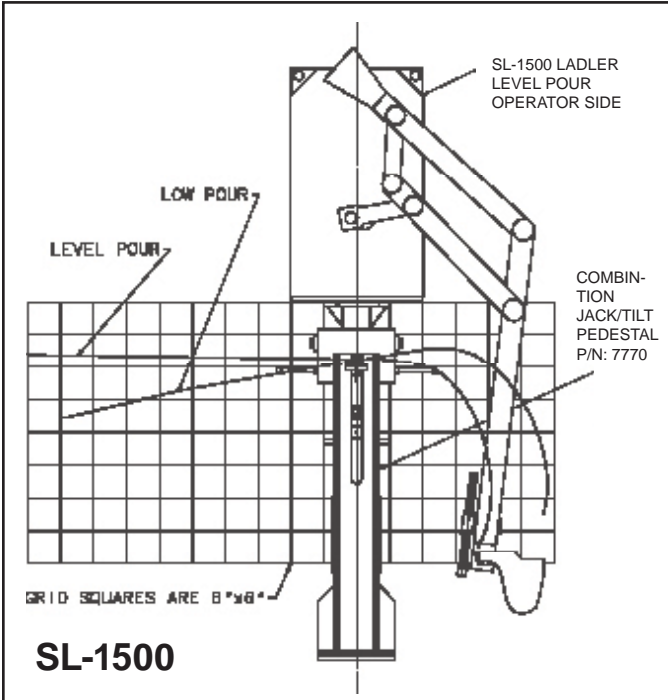

MODEL NUMBER	SL-1500(Lev)	SL-1500 (Low)
Total Stroke - Max.	88.5 in.(225 cm)	92 in.(234 cm)
Forward Stroke - Max.	63 in. (160 cm)	56 in. (142 cm)
Live Weight Metal	25 lb. (10 Kg)	25 lb. (10 Kg)
Reach Back (Furnace)	25.5 in. (65 cm)	36 in. (91 cm)

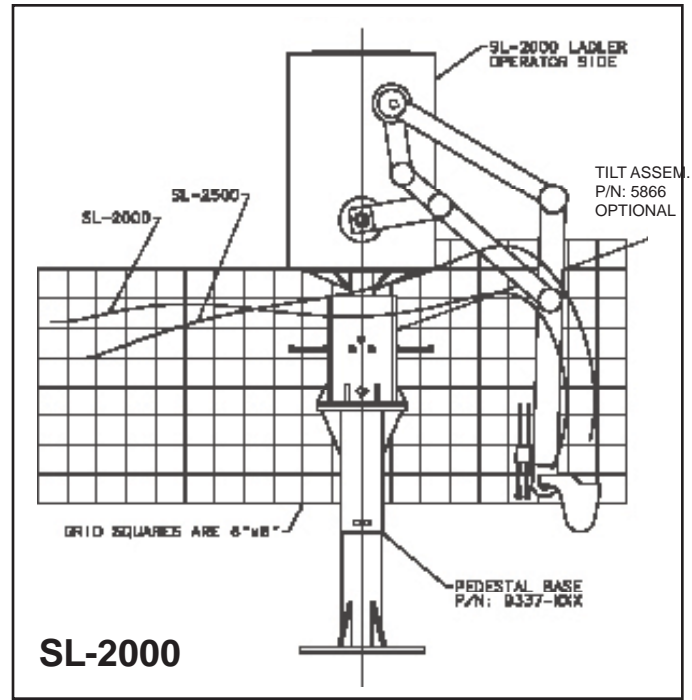

MODEL NUMBER	SL-2000 (Lev)
Total Stroke - Max.	104.8 in.(266 cm)
Forward Stroke - Max.	63 in. (160 cm)
Live Weight Metal	50 lbs. (23 Kg)
Reach Back (Furnace)	41.8 in. (106 cm)

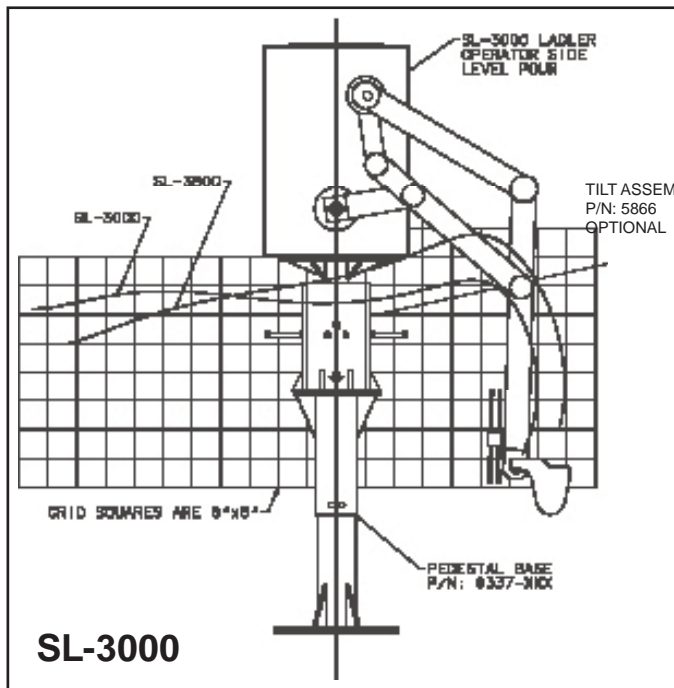

MODEL NUMBER	SL-3000 (Lev)	SL-3500 (Low)
Total Stroke - Max.	104.8 in. (266 cm)	102.5 in. (260 cm)
Forward Stroke - Max.	63 in. (160 cm)	55.5 in. (141 cm)
Live metal weight	100 lbs. (45 Kg)	100 lbs. (45 Kg)
Reach back into furnace	41.8 in. (106 cm)	47 in. (119 cm)

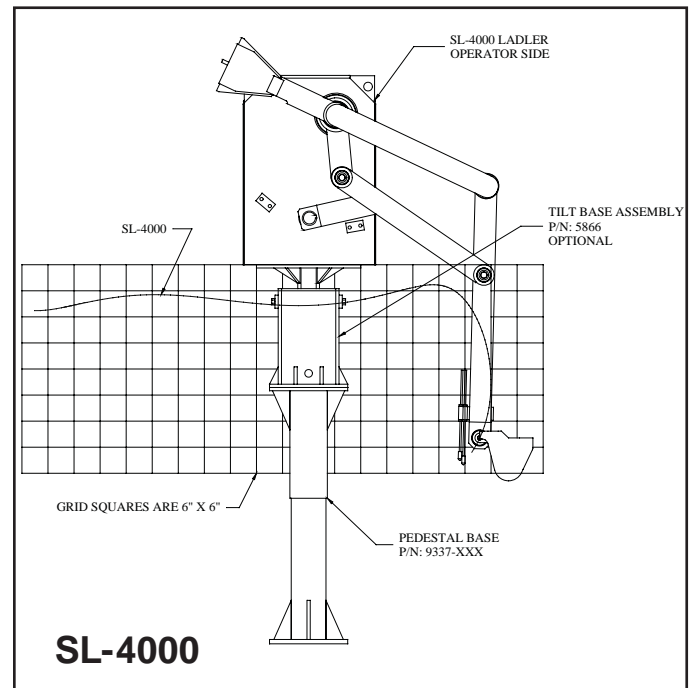

MODEL NUMBER	SL-4000 (Lev)
Total Stroke - Max.	104.8 in.(266 cm)
Forward Stroke - Max.	63 in. (160 cm)
Live Weight Metal	175 lbs. (80 Kg)
Reach Back (Furnace)	41.8 in. (106 cm)

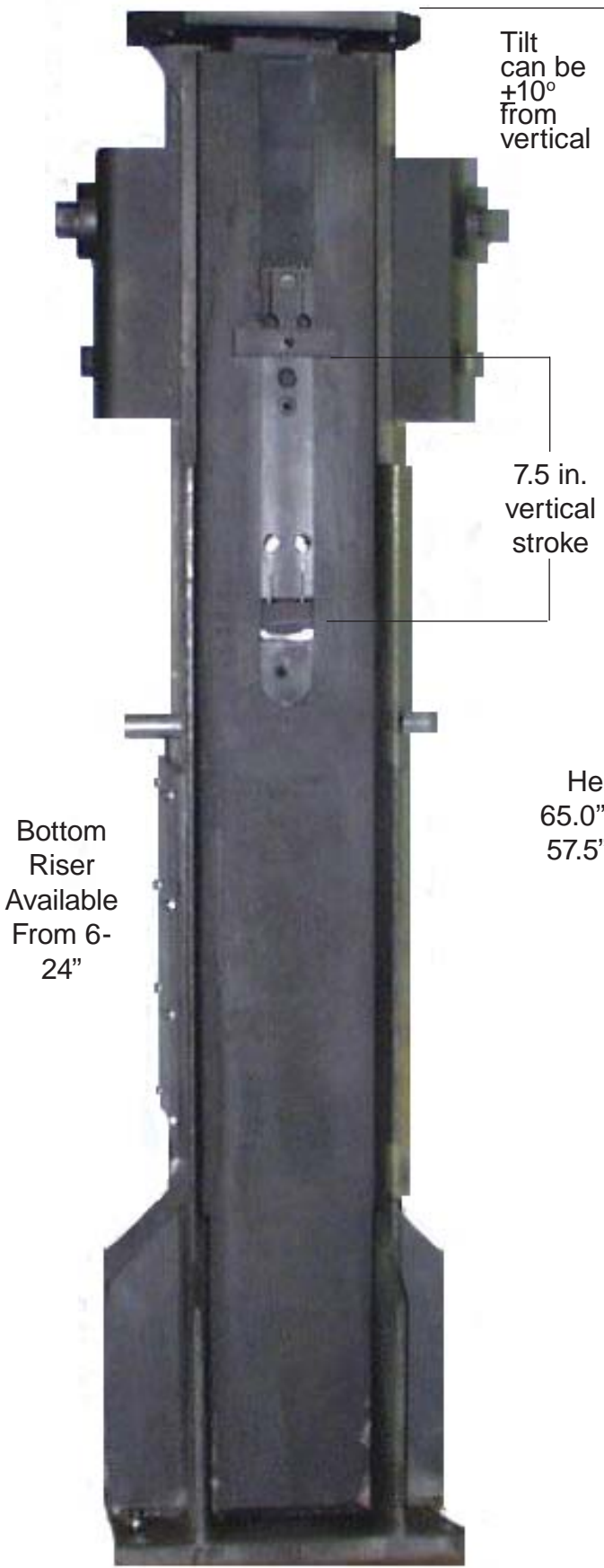

Tilt can be $\pm 10^\circ$ from vertical

7.5 in. vertical stroke

Bottom Riser Available From 6-24"

Height 65.0" max. 57.5" min.

#7770 COMBO TILT PEDESTAL (SL-650, SL-1400, and SL-1500 Only)



HEAVY-DUTY TILT ASSEMBLY (#5867 SL-1200, #5866 SL2000/3000)

Tilts $\pm 10^\circ$ from vertical.

Usually mounted on a standard pedestal.

Also can be used with an Advance Rotary Base.

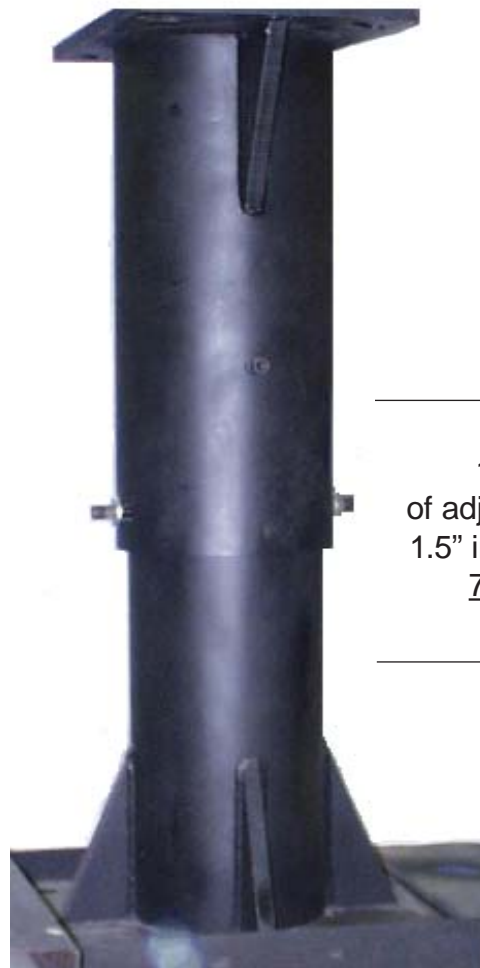

Collapsed Ht

- 36-1/2"
- 42-1/2"
- 48-1/2"
- 54-1/2"
- 60-1/2"
- 66-1/2"
- 72-1/2"

12 in. of adjustment in 1.5" increments
7 sizes

STANDARD PEDESTAL (#9337)

Ladle Cups

Advance Quick-Change Ladle Cups' pin-mount design means no tools are needed for changing cups.

Ladles are 1/4 to 5/16-inch thick, heat-treated cast iron for long life.

Made in the USA.

Sizes are available in both operator or helper side.



LADLE CUP # (Operator)	LADLE CUP # (Helper)	Rated Capacity		Minimum Furnace Size	
		in kg	in lbs.	Round 45° Angle of Entry	Square 45° Angle of Entry
0.5A	0.5B	0.5	1.1	17.25"	17.13 x 11.75
1.0A	1.0B	1.0	2.2	18.31"	18 x 12.13
1.5A	1.5B	1.5	3.3	18.75"	18.5 x 12.34
2.0A	2.0B	2.0	4.4	19.6"	19.25 x 13.25
2.5A	2.5B	2.5	5.5	19.75"	19.32 x 13.18
3.0A	3.0B	3.0	6.6	20"	19.69 x 14
3.5A	3.5B	3.5	7.7	20.45"	19.69 X 14.25
4.0A	4.0B	4.0	8.8	21.45"	20.84 x 16
6.0A	6.0B	6.0	13.2	22.5"	21.68 x 16.9
8.0A	8.0B	8.0	17.6	23.25"	22.28 x 18.13

Call us for additional information for new laminate ladle cups to 100# metal capacity. (New large cups are made with a steel fabric body that has a long life in molten aluminum. The cups have non-wetting surfaces that are resistant to thermal shock and breakage. The cups also insulate metal from heat loss during the delivery cycle for uniform product.)

Extensive Manuals

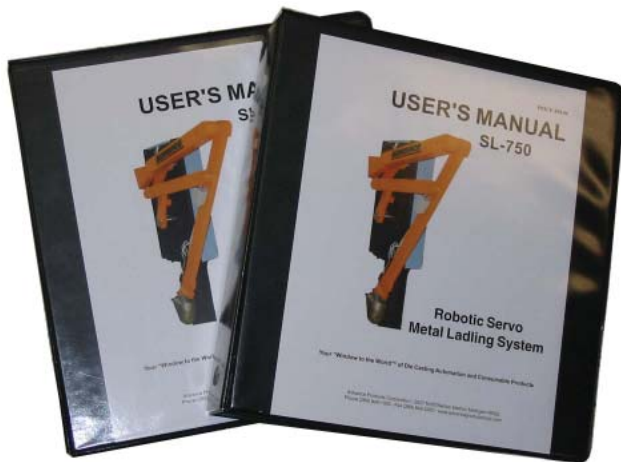

Customer Support Team

It's free! We don't charge for phone support. Call us!
1-616-249-1525

We would like to partner with you on your ladler needs! Give us a call!
1-616-249-1525

Advance

Advance®

SL-1400 Launder Servo Ladler

- Program storage capability of 500 alpha numeric programs.
- High lift capability from lower launder position.
- Eliminates need for furnace.
- 99%+ pouring Repeat ability.

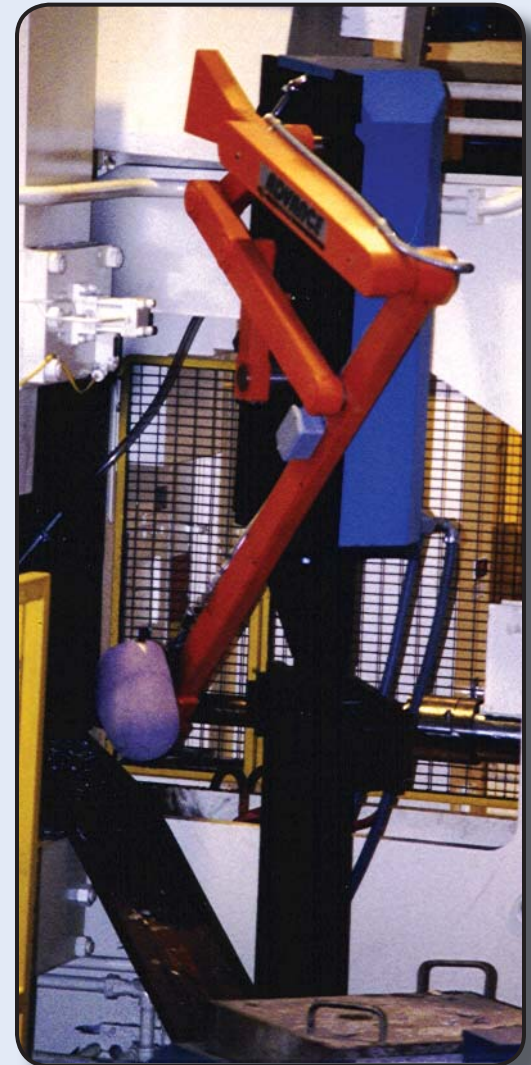
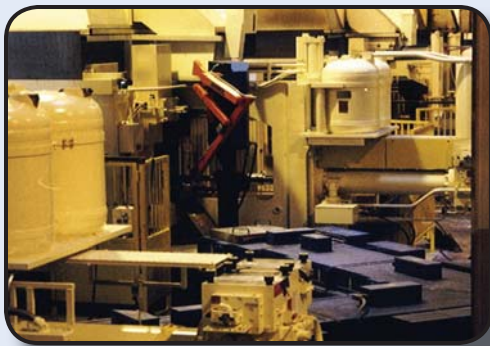

- | | |
|---|---------------|
| • Anti drip | 6" |
| • Shot size - pour weight repeat ability | 99%+ |
| • Pour speed changes | 3 |
| • Stroke programmable to | 72" |
| • Position accuracy | .020" |
| • Metal capacity | 25# |
| • Arm capacity | 50# |
| (Metal and cup combined) | |
| • Cycle rate (parts per hour) at 25# capacity | 140 (approx.) |
| • Standard length of cables (Specify length if different) | 30' |
| • Control box | |

Model SL-1400

For Die Casting Machines
800 ton to 1400 ton

CALL 616-249-1525 NOW FOR MORE INFORMATION!

The World of Automation and Consumables Solutions

Advance[®]

Specifications are subject
to change without notice.

Industrial Innovations, Inc. - 2936 Dormax Street SW - Grandville, Michigan 49418
Phone: 616-249-1525 - Fax: 616-249-0983

Printed in U.S.A.
APC-000-2010